



# Flygt 2750



---

# Table of Contents

Introduction.....	2
Specially approved products.....	2
Product Description.....	3
The data plate.....	3
Product denomination.....	3
Exploded Views.....	5
2750.390.....	5
Spare Parts.....	6
2750.390.....	6

# Introduction

## Purpose of this manual

The purpose of this manual is to provide necessary information on spare parts and accessories order.

## Disclaimer

Always use genuine Flygt parts. The use of other spare parts or accessories can invalidate any claims for warranty or compensation. Xylem does not take any responsibility for damages that are caused by the use of non-original parts. For more information, contact your local sales and service representative.

## Data for ordering spare parts

The following information is needed for spare part orders:

- Serial number of the product
- Part number
- Quantity of bulk material, see \* in tables

## Specially approved products

### Qualification of personnel

Only Xylem or Xylem-authorized service personnel may undertake repair work on Ex-approved products.

### Dimensional accuracy inspection

Spare parts marked with (Ex) after the part number are subject to dimensional accuracy inspection.

# Product Description

## Products included

Pump model	Approvals
2750.390	Standard European Norm (EN) <ul style="list-style-type: none"> <li>• ATEX Directive</li> <li>• EN 1127-1, EN 60079-0, EN 60079-15</li> <li>•  II 3G Ex nA/nC c IIC T1...T4</li> </ul>

## The data plate

The data plate is a metal label that is located on the main body of the products. The data plate lists key product specifications. Specially approved products also have an approval plate.

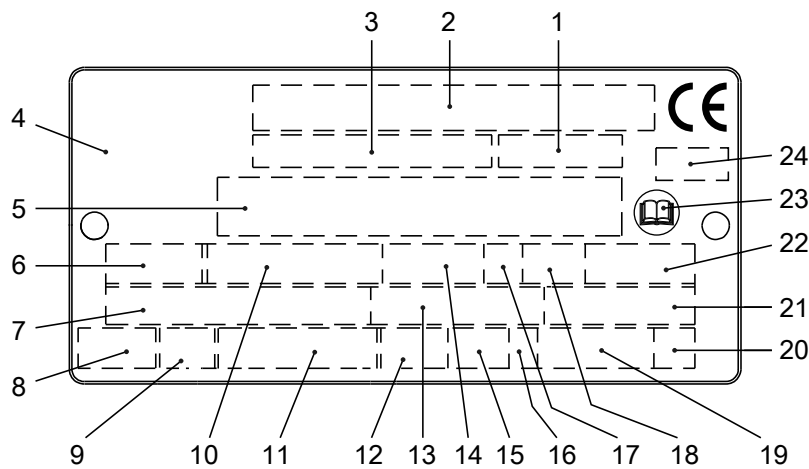

1. Curve code or Propeller code
2. Serial number, see [Product denomination](#) (page 3)
3. Product number
4. Country of origin
5. Additional information
6. Phase; type of current; frequency
7. Rated voltage
8. Thermal protection
9. Thermal class
10. Rated shaft power
11. International standard
12. Degree of protection
13. Rated current
14. Rated speed
15. Maximum submergence
16. Direction of rotation: L=left, R=right
17. Duty class
18. Duty factor
19. Product weight
20. Locked rotor code letter
21. Power factor
22. Maximum ambient temperature
23. Read installation manual
24. Notified body, only for EN-approved Ex products

Figure 1: The data plate

## Product denomination

### Reading instruction

In this section, code characters are illustrated accordingly:

X = letter

Y = digit

The different types of codes are marked up with a, b and c. Code parameters are marked up with numbers.

Codes and parameters

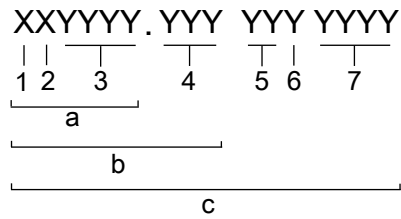

Type of Callout	Number	Indication
Type of code	a	Sales denomination
	b	Product code
	c	Serial number
Parameter	1	Hydraulic end
	2	Type of installation
	3	Sales code
	4	Version
	5	Production year
	6	Production cycle
	7	Running number

# Exploded Views

2750.390

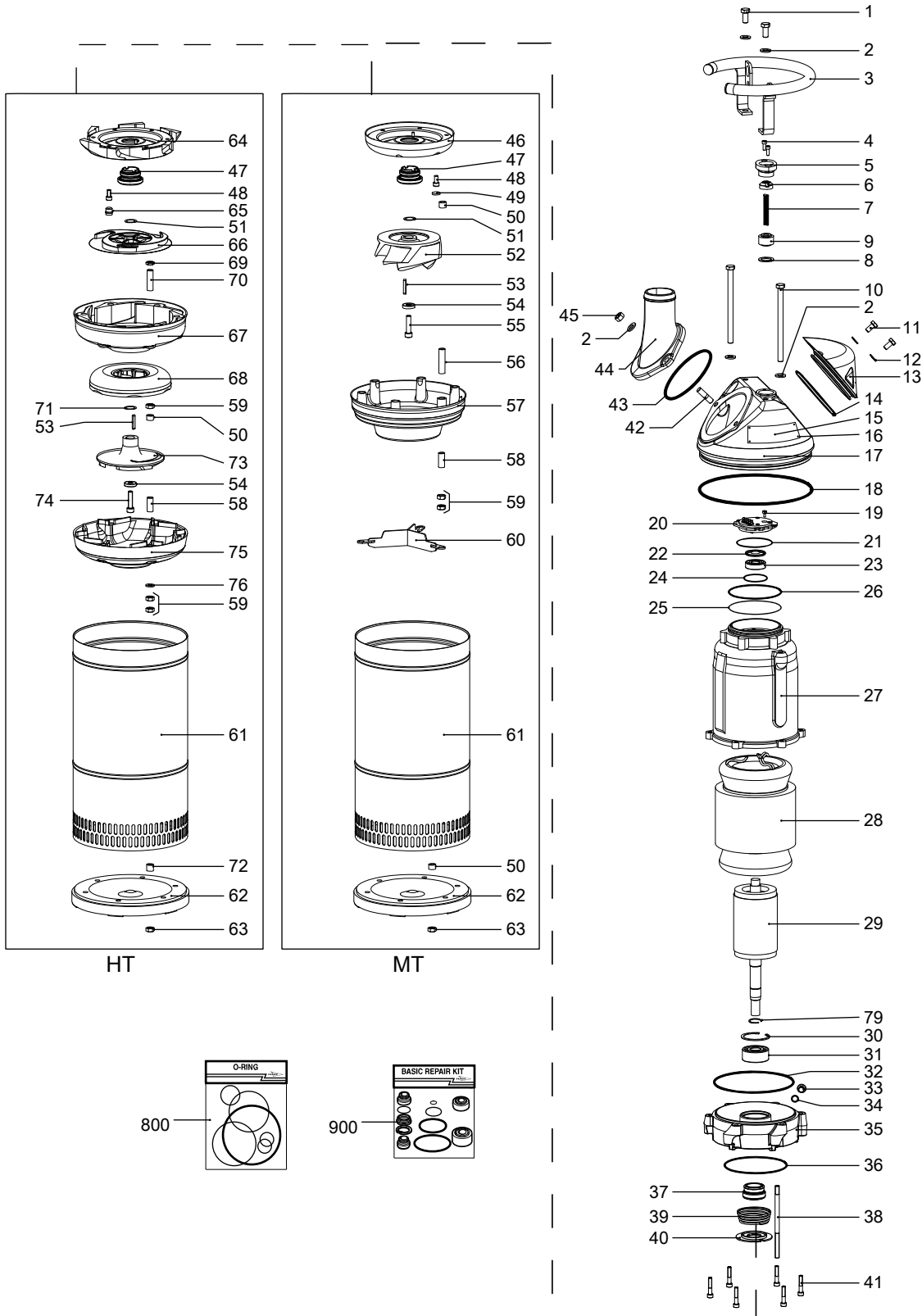

20216A\_2750\_390\_HT\_MT\_exp\_view

# Spare Parts

2750.390

Pos. No	Part. No	Denomination	Qty/ Version
			390
1	81 49 05	Hexagon head screw M12X25-A4-70	2
2	82 35 77	Plain washer A4-A170	2
3	680 81 00	Handle	1
4	83 02 77	Hex.socket hd screw M6X20-A4-70	2
5	640 89 04	Entrance flange	Cable entry (16)-18mm Cable entry (20)-22mm 1
5	673 30 00	Entrance flange ISO G1	Cable entry for metal hose (16)-18mm Cable entry for metal hose (20)-22mm 1
5	640 89 02	Entrance flange	Cable entry (22)-26mm 1
6	678 58 18	Cable clip (16)-18 MM	1
6	678 58 22	Cable clip (20)-22 MM	1
6	678 58 24	Cable clip (22)-24 MM	1
6	678 58 26	Cable clip (24)-26 MM	1
7	94 20 59	Motor cable subcab	SUBCAB 4G2,5+2x1,5 17 - 18mm *
7	94 20 82	Motor cable subcab	SUBCAB 7G2,5+2x1,5 20 - 23mm Star delta possible *
7	94 20 60	Motor cable subcab	SUBCAB 4G4+2x1,5 20 - 22mm *
7	94 21 06	Motor cable	SUBCAB 10AWG/3-2-1-GC 20,30 - 22,30mm *
8	82 40 61	Plain washer (10)-22 MM	1
8	82 40 62	Plain washer (24)-26 MM	1
9	84 17 93	Seal sleeve (16)-18 MM	1
9	84 17 95	Seal sleeve (20)-22 MM	1
9	84 17 96	Seal sleeve (22)-24MM	1
9	84 17 97	Seal sleeve (24)-26MM	1
9	84 15 89	Seal sleeve (16)-18 MM	1
10	81 46 75	Hexagon head screw	2
11	81 48 79	Hexagon head screw M10X20-A4-70	2
12	82 35 76	Plain washer 10-A4-170	2
13	679 08 00	Connection cover	1
14	82 81 83	O-ring 129.3X5.7 FPM	1
15	630 68 02	Data plate	1
16	82 21 73	Drive screw 4X5-A4	2
17	679 07 00	Cover	1
18	82 80 87	O-ring 249.3X5.7 FPM	1
19	81 44 02	Slotted head screw	4
20	710 90 02	Connection term board	Terminal board Max 690V For star-delta start 1
20	710 90 01	Connection term board	Terminal board Max 690V For DOL start 1



Pos. No	Part. No	Denomination	Qty/ Version	
			390	
21	80 94 49	O-ring 74.61X3.53 FPM	1	
22	710 61 00	Bearing cover	1	
23	83 32 35	Ball bearing	1	
24	80 94 48	O-ring 47.2X3.53 FPM	1	
25	82 81 59	O-ring 119.5X3 FPM	1	
26	80 94 44	O-ring 117.5X5.34 FPM	1	
27	712 01 00	Stator housing	1	
28	711 92 07	Stator 19-14-2a	6-leads 50 Hz 380V-415V D P2=8kW	1
28	711 92 09	Stator 19-14-2a	6-leads 50 Hz 500V-550V D P2=8kW	1
28	711 92 14	Stator 19-14-2a	9-leads 60 Hz 440V-480V YSER 220V-240V Y// P2=9,70kW/13hp	1
28	711 92 16	Stator 19-14-2a	6-leads 60 Hz 575V-600V D P2=9,70kW/13hp	1
29	711 93 01	Shaft unit	1	
30	82 62 12	Retaining ring SGH 62	1	
31	83 30 15	Ball bearing 3305A-2Z/C3VT113	1	
32	82 71 42	O-ring 183.5X3 FPM	1	
33	710 45 01	Inspection screw	1	
34	81 78 65	O-ring 12.37X2.62 FPM	1	
35	711 02 00	Bearing holder	1	
36	82 71 43	O-ring 156X3 FPM	1	
37	712 56 00	Mechanical seal	1	
38	711 35 22	Stud	6	
39	712 68 01	Compression spring	1	
40	713 87 00	Plate	1	
41	83 03 04	Hex.socket hd screw M8X40-A4-70	6	
42	84 94 87	Stud	2	
43	82 81 04	O-ring 139.3X5.7 FPM	1	
44	680 26 00	Discharge connection	DN 75 Hose	1
44	680 55 00	Discharge connection	DN 75 Thread : ISO G3A Outer Quick coupling: Storz	1
44	680 55 02	Discharge connection	DN 75 Thread : NPT 3-8 Outer	1
44	680 76 00	Discharge connection	DN 100 Hose	1
44	680 56 00	Discharge connection	DN 100 Thread : ISO G4A Outer Quick coupling: Storz diam=115 mm	1
44	680 56 02	Discharge connection	DN 100 Thread : NPT 4-8 Outer	1
45	82 23 35	Hexagon nut M12-A4-70	2	
46	712 78 03	Oil housing coated	1	
47	713 90 00	Mechanical seal	1	
48	83 02 97	Hex.socket hd screw M8X16-A4-70	6	
49	710 52 00	Protective washer	6	
50	710 28 02	Sleeve	6-12	
51	710 43 01	Adjusting washer	10	
52	713 93 00	Impeller	241 MT 50Hz	1
52	713 93 01	Impeller	242 MT 60Hz	1
53	83 48 42	Parallel key	1	
54	82 34 55	Plain washer	1	

Pos. No	Part. No	Denomination	Qty/ Version
			390
55	84 41 93	Hex.socket hd screw	1
56	711 37 15	Spacing sleeve	6
57	712 02 02	Diffuser coat.	1
58	711 37 13	Spacing sleeve	6
59	82 23 33	Hexagon nut M10-A4-70	12
60	711 99 02	Antirotation device	1
61	680 54 00	Strainer	1
62	713 72 00	Strainer bottom	1
63	82 27 28	Lock nut M10-A4-70	6
64	712 78 04	Oil housing coated	1
65	710 30 00	Protective plug	6
66	713 92 00	Impeller	266 HT 50Hz
66	713 92 01	Impeller	267 HT 60Hz
67	712 00 00	Diffuser coat.	1
68	712 06 02	Diffuser coat.	1
69	82 25 41	Hexagon nut	6
70	711 37 14	Spacing sleeve	6
71	712 07 01	Adjusting washer	10
72	710 28 03	Sleeve	6
73	713 94 00	Impeller	266 HT 50Hz
73	713 94 01	Impeller	267 HT 60Hz
74	83 03 26	Hex.socket hd screw M10X40-A4-70	1
75	711 42 02	Diffuser coat.	1
76	82 34 25	Plain washer 8-A4-140HV	6
77	710 28 02	Sleeve	6
78	82 35 77	Plain washer A4-A170	2
79	82 63 86	Retaining ring 25-SPRING STEEL	1
80	82 35 77	Plain washer A4-A170	2
81	82 23 33	Hexagon nut M10-A4-70	6
82	83 20 10	Coupling part	DN 75 Thread : ISO G3A Outer Quick coupling: Storz
82	83 20 12	Coupling part	DN 100 Thread : ISO G4A Outer Quick coupling: Storz
82	83 20 11	Coupling part	DN 100 Thread : ISO G4A Outer Quick coupling: Storz diam=115 mm
83	90 17 52	Oil ISO VG 32	*
84	83 41 83	Insulating sleeve 0.5-6 MM2	5-8
85	83 41 89	Flat pin sleeve 1-2.5MM2	6
86	83 42 96	Cable lug 2.5-6 MM2;M6	1-2
87	83 41 83	Insulating sleeve 0.5-6 MM2	4-5
88	83 41 89	Flat pin sleeve 1-2.5MM2	2-8
88	84 92 75	Flat pin sleeve 2.5-6MM2	3-5
89	766 71 00	Connection plate	1
91	340 71 00	Instruction plate	1
92	667 40 01	Sticker	2
93	83 41 84	Flat pin sleeve 0.75-1.5MM2	2-8

Pos. No	Part. No	Denomination	Qty/ Version
			390
94	83 43 58	Cable lug INSUL.UL/CSA 1.04-2.6 MM2	1
95	81 73 72	Slotted head screw M6X10-A4-70	1
96	94 05 86	Insulating hose D=12 MM	*
97	427 13 00	Marking tape	1
98	83 44 24	Closed-end splice 3-6(AWG 12-10) L=18	3
99	718 05 00	Sticker CUT HAZARD	1
800	694 81 00	O-ring kits	1
801	783 46 00	Zinc anode kit	1
815	554 30 16	Starter	1
		Starter 351 50/60 Hz 380V - 415 V Current range: 13 - 18 A supervision Phase sequence indicator Supply connection CEE 5-PLUG 32A	
815	554 21 06	Starter	1
		Starter 356 50/60 Hz Max 600 V Current range: 13 - 18 A supervision	
900	694 82 00	Basic repair kit	1



**ООО «Бауманс Груп» - официальный партнер фирмы Flygt в России.**

**Тел: +7 495 121 49 50**

**Эл. почта: [info@baumgroup.ru](mailto:info@baumgroup.ru)**

**Сайт: [www.baumgroup.ru](http://www.baumgroup.ru)**